

CART-DUMPING SYSTEMS

Marathon® Cart Dumpers

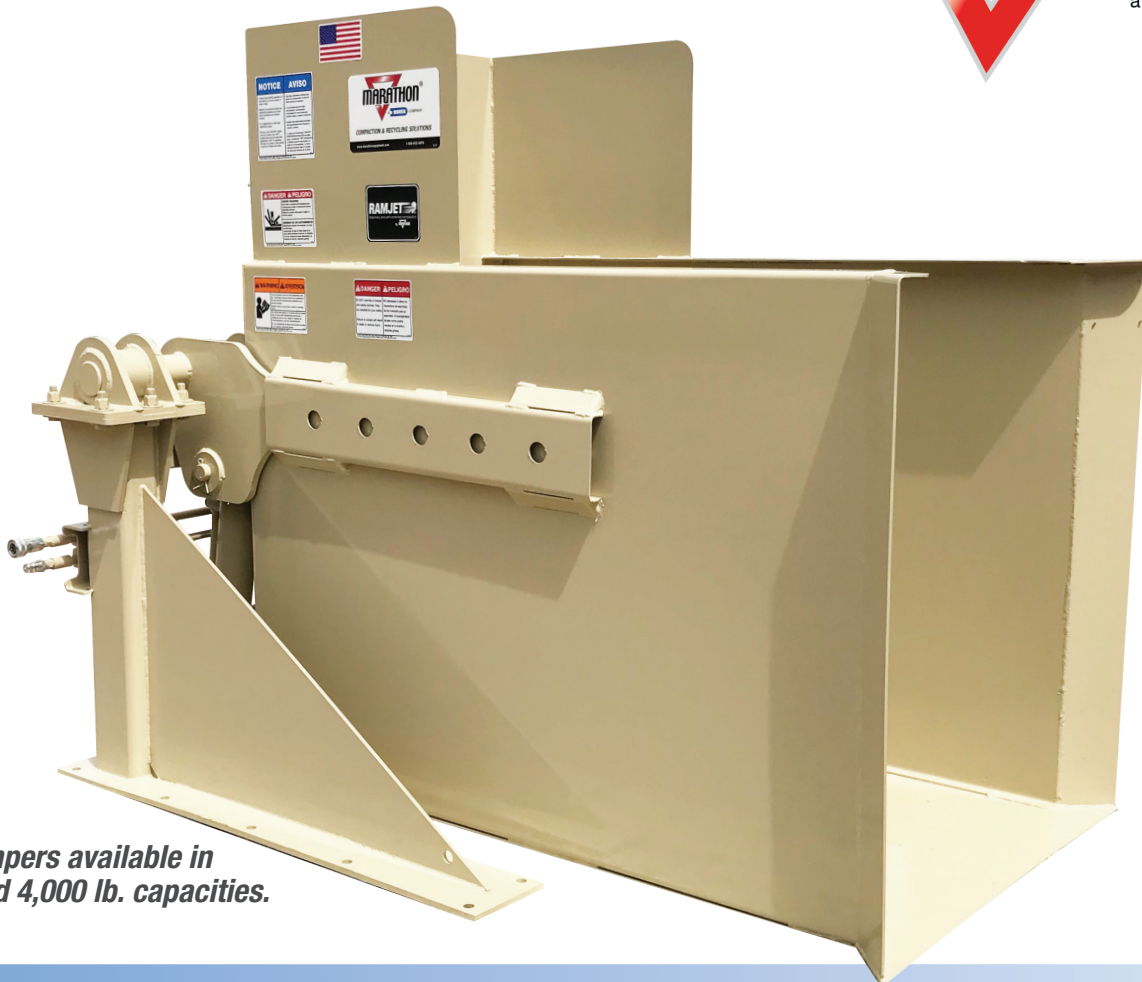

Cart Dumpers available in 2,000 and 4,000 lb. capacities.

Cart Dumper Features

- ▼ *For plastic and steel containers from .5 to 4.0 cubic yards*
- ▼ *Reliable performance in commercial and industrial applications*
- ▼ *Standard and heavy-duty models available*
- ▼ *Tilt-truck boxes available in a variety of configurations*

The Worldwide Leader in Quality Recycling and Compaction Equipment

Marathon® Equipment is known throughout the world as one of the leading manufacturers of quality on-site recycling products. The **Marathon** brand has been the industry standard for quality and innovation for more than 50 years, and includes auto-tie balers, manual-tie balers, two-ram balers, MRF systems, conveyors, vertical balers, auger-style compactors, cart dumpers, and a wide array of options for virtually any application.



Environmental Solutions Group®

a DOVER company



CART-DUMPING SYSTEMS



Marathon® Cart Dumpers

Overview

Perfect for:

-  Transfer Stations
-  Municipal Recycling Drop-Off Centers
-  Large Warehouses
-  Distribution Centers
-  Manufacturing Facilities



The Smart, Cost-Effective Way to Compact

Marathon® Cart Dumpers can extend the benefits of compaction to all areas of your operation while minimizing equipment investments.

Marathon standard Cart Dumpers are designed to handle two-, three-, and four-cubic-yard “trainable” steel containers or a wide variety of plastic tilt-carts in most sizes.



Ground-Level Dumpers

Ground Level Dumpers are used to dump containers at ground level into your stationary or self-contained compactor. They are ideal for park systems, shopping malls, and large or multi-building plants.

Control Station

Marathon Cart Dumpers feature an advanced, simplified three-button control system. It is key-operated, fully automatic, and contained in a weatherproof NEMA 4 enclosure. Connected to the power pack with 13' of conduit, the controls can be located for operator convenience.



For more information or to order, call 1-800-633-8974 or visit us at www.marthonequipment.com

CART-DUMPING SYSTEMS



Marathon® Cart Dumpers

Overview

Dock-Level Dumpers

Dock-Level Dumpers are used to dump containers that are rolled directly onto a stationary compactor, or used with self-contained units next to a dock. They are ideal for industrial plants where waste accumulates in many locations. Standard units are powered by a separate 3-hp, 3-gpm power pack with on/off controls and a sustained manual pressure control. Heavy-duty units are powered by a 10-hp, 10-gpm power pack with the same controls as Standard Units. This enables the operator to effectively manage any stage of the dumping process.



Tilt-Cart Dumpers

Tilt-Cart Dumpers handle molded plastic tilt-trucks, steel carts, and Gaylord boxes. They are designed to hold the tilt-truck during dumping without the need for mechanical locks.

Fork-Style Dumpers

Marathon Fork-Style Dumpers handle carts/containers with integrated fork pockets.

Other Cart Dumpers

Integral Dumpers - Cart Dumpers for Self-Contained Compactors, available for both fork- or tilt-carts.

Cart Tippers - Lifting solutions for Stationary, Self-Contained, and Pak'ntainer® compactors to dump 90- and 96-gallon containers.

Marathon RJ-250
Compactor with integral
dumper for fork-style
carts. For information on
our Integral Dumpers,
contact your **Marathon** Sales
Representative.



Bayne Thinline® cart lifters work with
standard 2-bar roll-out carts
and can lift up to 750 lbs. Lifter
has a powder-coated finish so
it can stand up to the elements.
For information on our Bayne
Cart Lifters, contact your
Marathon Sales Representative.



For more information or to order, call 1-800-633-8974 or visit us at www.marathonequipment.com

CART-DUMPING SYSTEMS



Marathon® Cart Dumpers

Features & Specifications

The Cart Dumper In Action:

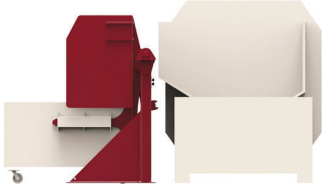

Container is rolled into dumper-fork arms or tilt-truck box. The **Marathon** power pack is activated from outside the area of operation.

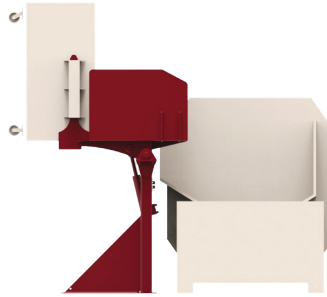

Special guards prevent spillage or leakage, even in the vertical position. Operator has full control of the cycle at all times.

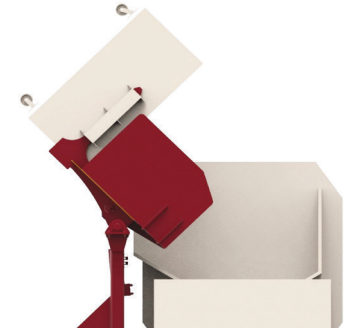

Container is tilted a full 45 degrees past vertical, assuring complete cleanout.

Dimensions & Specifications

Performance Characteristics		
Cycle Time	41 sec.	30 sec.
Tilt-Truck Weight Capacity	1,650 lbs. (748 kg)	3,650 lbs. (1,655 kg)
Fork-Style Weight Capacity	2,000 lbs. (907 kg)	4,000 lbs. (1,814 kg)
Electrical Equipment		
Electrical Motor 3/60-208/230/460/575	3 hp (2.2 kW)	10 hp (7.5 kW)
Standard Controls Include	Three-Push Button Station: Keylock Start/Stop/Reverse	
Hydraulic Equipment		
	Standard	Heavy-Duty
Hydraulic Cylinders	2	
Bore	3 1/8" (79mm)	4" (100mm)
Rod	1 1/2" (38mm)	2" (51mm)
Stroke	17 1/4" (438mm)	17 1/4" (438mm)
Maximum System Pressure	1,650 psi (113.8 bar)	1,965 psi (135.5 bar)
Hydraulic Pump Capacity	3 gpm (11.4 L/min)	10 gpm (37.9 L/min)

Load capacities are calculated using the following criteria:

- Loads being uniformly distributed in the cart
- Load capacity includes weight of cart
- Tilt-truck style dumpers assume a load centered at 32" from back of tilt-truck box
- Fork-style dumpers assume a load centered at 36" from the cart-stop crossbar

Pictures and mechanical diagrams in this literature are illustrative only and may not be to scale. Specifications are subject to change without notice in order to accommodate improvements to the equipment. Certified in compliance with ANSI standard Z245.2 and all applicable OSHA Regulations. Products must be used only by trained operators in accordance with the Operator Manual, as well as applicable regulations, laws, and ANSI standards.

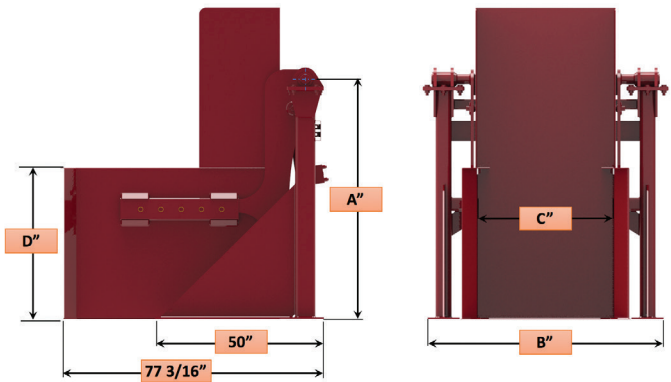

Tilt-Truck Style Cart Dumper

- A - Pivot Height** - Available in 36", 48", 60" and 72"
- B - Overall Width** - Available in 58 3/4" to 73 1/2"
- C - Tilt-Truck Spacing** - Available in 34 1/8" to 48 7/8"
- D - Tilt-Truck Box Height** - Standard Tilt-Truck Box Height "D" is 45 7/16"

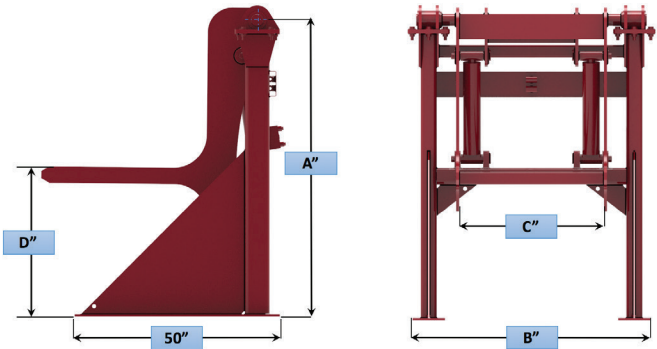

Fork-Style Cart Dumper

- A - Pivot Height** - Available in 36", 48", 60" and 72"
- B - Overall Width** - Available in 58 3/4" to 73 1/2"
- C - Fork Spacing** - Available in 35 1/8" to 50 1/2"
- D - Standard Fork Height** - Standard Fork Height "D" is 36"



Marathon Equipment Company | P.O. Box 1798 | Vemon, AL 35592-1798

Learn more about Marathon Equipment: 800.633.8974 | www.marthonequipment.com

© 2021 Marathon Equipment Company. All rights reserved.