

## Closed-End

Horizontal Baler



### Closed-End Features

- ▼ Wide variety of feed openings available to accommodate your specific material size
- ▼ Compatible with conveyor, chute, cart dumper, or hand-feed applications
- ▼ Standard photocell feature enables automatic cycling
- ▼ Standard touchscreen controls, hydraulic door latch, and rotary bale-length gauge facilitate easy operation

### The Worldwide Leader in Quality Recycling and Compaction Equipment

Marathon® Equipment is known throughout the world as one of the leading manufacturers of quality on-site recycling products. The **Marathon** brand has been the industry standard for quality and innovation for more than 50 years, and includes auto-tie balers, manual-tie balers, two-ram balers, MRF systems, conveyors, vertical balers, auger-style compactors, cart dumpers, and a wide array of options for virtually any application.



**Environmental  
Solutions Group®**

a DOVER company

## Closed-End Horizontal Baler

### Overview



Marathon® Closed-End Horizontal Balers are mid-sized balers that process a wide variety of material and can produce up to 20 tons of OCC in a typical shift.

### Key Features

- ▼ Rotary bale-length gauge activates the bale made light automatically, with no flag pole to engage or disengage
- ▼ A photoelectric cell enables automatic cycling
- ▼ Heavy-duty, spring-loaded retainer locks
- ▼ Reversible and replaceable ram-shear blade and serrated body-shear blade
- ▼ Conveyor, chute, or hand-feed hopper
- ▼ Heavy-duty power pack with 20 or 30 HP (Totally Enclosed Fan-Cooled) TEFC motor
- ▼ Center position valve, 10-micron return-line filter, and 100 mesh suction-line strainer
- ▼ Audio/visual start-up alarm

## Closed-End Horizontal Baler

### Features and Dimensions



Marathon® Closed-End Balers feature a hydraulic door latch, standard on all models.



The touchscreen enables full automatic and manual control with one touch. Screens may be customized, password protected, and are designed with alarm, diagnostic, and help screens.



High-efficiency power unit and electrical disconnect are standard on all Marathon® Closed-End Horizontal Balers.

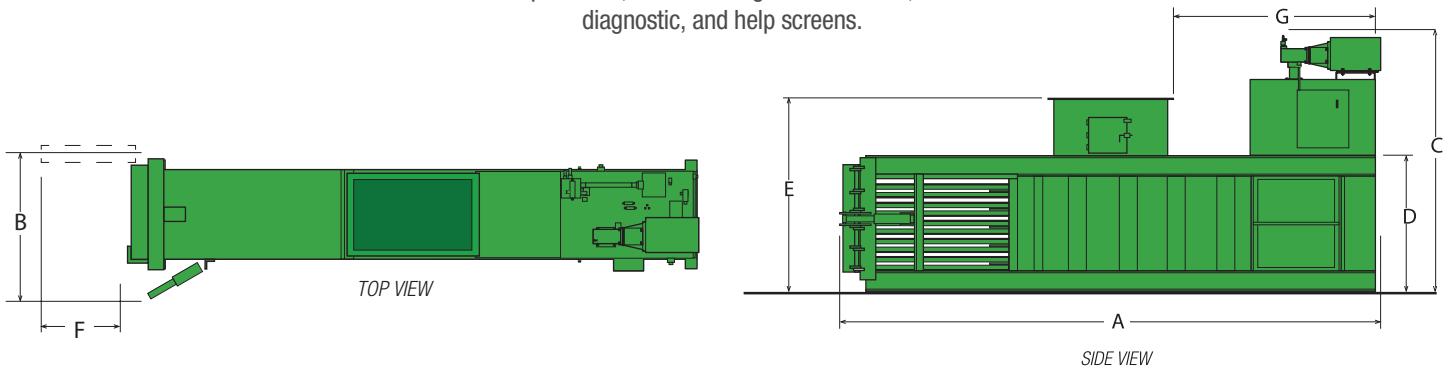

### Closed-End Horizontal Baler Dimensions

Specifications	A Overall Length	B Overall Width	C Overall Height	D Body Height	E Feed Height	F Door Opening Length	G Rear of Unit to Charge Box Opening
<b>CE-303042-720</b>	18' 9" 5715mm	60 9/16" 1538mm	103 1/2" 2629mm	55 1/8" 1400mm	92" 2337mm	43 3/8" 1102mm	97" 2464mm
<b>CE-503042-720</b>	20' 5" 6223mm	60 9/16" 1524mm	103 1/2" 2629mm	55 1/8" 1400mm	92" 2337mm	43 3/8" 1102mm	97" 2464mm
<b>CE-503042-830</b>	20' 5" 6223mm	60 9/16" 1524mm	103 1/2" 2629mm	55 1/8" 1400mm	92" 2337mm	43 3/8" 1102mm	97" 2464mm
<b>CE-504242-830</b>	20' 5" 6223mm	70 9/16" 1792mm	103 1/2" 2629mm	55 1/8" 1400mm	92" 2337mm	55 3/8" 1406mm	97" 2464mm
<b>CE-504842-830</b>	20' 5" 6223mm	76 9/16" 1945mm	103 1/2" 2629mm	55 1/8" 1400mm	92" 2337mm	61 3/8" 1559mm	97" 2464mm
<b>CE-604242-830</b>	22' 3" 6782mm	70 9/16" 1792mm	103 1/2" 2629mm	55 1/8" 1400mm	92" 2337mm	55 3/8" 1406mm	97" 2464mm
<b>CE-604842-830</b>	22' 3" 6782mm	76 9/16" 1945mm	103 1/2" 2629mm	55 1/8" 1400mm	92" 2337mm	61 3/8" 1559mm	97" 2464mm
<b>CE-724842-830</b>	25' 6" 7772mm	76 9/16" 1945mm	103 1/2" 2629mm	55 1/8" 1400mm	92" 2337mm	61 3/8" 1559mm	135" 3429mm

Pictures and mechanical diagrams in this literature are illustrative only and may not be to scale. Specifications are subject to change without notice in order to accommodate improvements to the equipment. Certified in compliance with ANSI standard Z245.2 and all applicable OSHA Regulations. Products must be used only by trained operators in accordance with the Operator Manual, as well as applicable regulations, laws, and ANSI standards.

## Closed-End Horizontal Baler

### Dimensions and Specifications

Specifications	CE-303042-720	CE-503042-720	CE-503042-830	CE504242-830	CE-504842-830	CE-604242-830	CE-604842-830	CE-724842-830
<b>Feed Opening (L x W)</b>	30 5/16" x 27 3/4" 770mm x 705mm	50 5/16" x 27 3/4" 1278mm x 705mm	50 5/16" x 27 3/4" 1278mm x 705mm	50 5/16" x 39 3/4" 1278mm x 1010mm	50 5/16" x 45 3/4" 1278mm x 1162mm	50 5/16" x 39 3/4" 1278mm x 1010mm	60 5/16" x 45 3/4" 1532mm x 1162mm	72 5/16" x 45 3/4" 1837mm x 1162mm
<b>Bale Weight (OCC)</b>	Up to 1,400 lbs. Up to 635 kg	Up to 1,400 lbs. Up to 635 kg	Up to 1,500 lbs. Up to 680 kg	Up to 1,800 lbs. Up to 816 kg	Up to 1,800 lbs. Up to 816 kg	Up to 1,800 lbs. Up to 816 kg	Up to 2,000 lbs. Up to 907 kg	Up to 2,000 lbs. Up to 907 kg
<b>Nominal Bale Size (W x H x L)</b>	32" x 42" x 72" 813mm x 1067mm x 1829mm	32" x 42" x 72" 813mm x 1067mm x 1829mm	32" x 42" x 72" 813mm x 1067mm x 1829mm	42" x 42" x 72" 1067mm x 1067mm x 1829mm	48" x 42" x 72" 1219mm x 1067mm x 1829mm	42" x 42" x 72" 1067mm x 1067mm x 1829mm	48" x 42" x 72" 1219mm x 1067mm x 1829mm	48" x 42" x 72" 1219mm x 1067mm x 1829mm
<b>Unit Weights*</b>	13,800 lbs. 6260 kg	14,400 lbs. 6532 kg	14,900 lbs. 6759 kg	16,600 lbs. 7530 kg	17,400 lbs. 7893 kg	17,100 lbs. 7756 kg	18,100 lbs. 8210 kg	19,700 lbs. 8936 kg
<b>Performance Characteristics</b>								
<b>Cycle Time</b>	22 seconds	22 seconds	20 seconds	20 seconds	20 seconds	20 seconds	22 seconds	27 seconds
<b>Maximum Baling Force</b>	96,200 lbs. 428 kN	96,200 lbs. 428 kN	125,700 lbs. 559 kN	125,700 lbs. 559 kN	125,700 lbs. 559 kN	125,700 lbs. 559 kN	125,700 lbs. 559 kN	125,700 lbs. 559 kN
<b>Platen Pressure</b>	79 psi 544.7 kPa	79 psi 544.7 kPa	104 psi 717.1 kPa	74 psi 510.2 kPa	65 psi 448.2 kPa	74 psi 510.2 kPa	65 psi 448.2 kPa	65 psi 448.2 kPa
<b>Electrical Equipment</b>								
<b>Electric Motor 3/60-208/230/460</b>	20 hp 15 kW	20 hp 15 kW	30 hp 22 kW	30 hp 22 kW	30 hp 22 kW	30 hp 22 kW	30 hp 22 kW	30 hp 22 kW
<b>Hydraulic Equipment</b>								
<b>Pump Capacity</b>	50 gpm 189 L/min	50 gpm 189 L/min	75 gpm 284 L/min	75 gpm 284 L/min	75 gpm 284 L/min	75 gpm 284 L/min	75 gpm 284 L/min	75 gpm 284 L/min
<b>Operating Pressure</b>	2,500 psi 172 bar	2,500 psi 172 bar	2,500 psi 172 bar	2,500 psi 172 bar	2,500 psi 172 bar	2,500 psi 172 bar	2,500 psi 172 bar	2,500 psi 172 bar
<b>Reservoir</b>	150 gal. 568 L	150 gal. 568 L	150 gal. 568 L	150 gal. 568 L	150 gal. 568 L	150 gal. 568 L	150 gal. 568 L	150 gal. 568 L
<b>Cylinder(s)</b>	1	1	1	1	1	1	1	1
<b>Bore</b>	7" 178mm	7" 178mm	8" 203mm	8" 203mm	8" 203mm	8" 203mm	8" 203mm	8" 203mm
<b>Rod</b>	4 1/2" 114mm	4 1/2" 114mm	4 1/2" 114mm	4 1/2" 114mm	4 1/2" 114mm	4 1/2" 114mm	4 1/2" 114mm	4 1/2" 114mm
<b>Stroke</b>	68" 1727mm	68" 1727mm	68" 1727mm	68" 1727mm	68" 1727mm	68" 1727mm	78" 1981mm	90" 2286mm

\*The baler foundation must be a minimum of 6" thick, 3000 psi steel-reinforced concrete. It is recommended that the baler be positioned on a 3/4" steel foundation plate to prevent possible floor damage

Pictures and mechanical diagrams in this literature are illustrative only and may not be to scale. Specifications are subject to change without notice in order to accommodate improvements to the equipment. Certified in compliance with ANSI standard Z245.2 and all applicable OSHA Regulations. Products must be used only by trained operators in accordance with the Operator Manual, as well as applicable regulations, laws, and ANSI standards.

#### We're Here To Help!

For detailed specifications, recommendations, or to request a site survey comparing various systems, contact the Marathon® Sales Team at [MarathonSales@MarathonEquipment.com](mailto:MarathonSales@MarathonEquipment.com)

#### Authorized Dealer:



Marathon Equipment Company | P.O. Box 1798 | Vernon, AL 35592-1798

Learn more about Marathon Equipment: 800.633.8974 | [www.marathonequipment.com](http://www.marathonequipment.com)